

REVISIONS			
REV.	DESCRIPTION	DATE	DRAWN

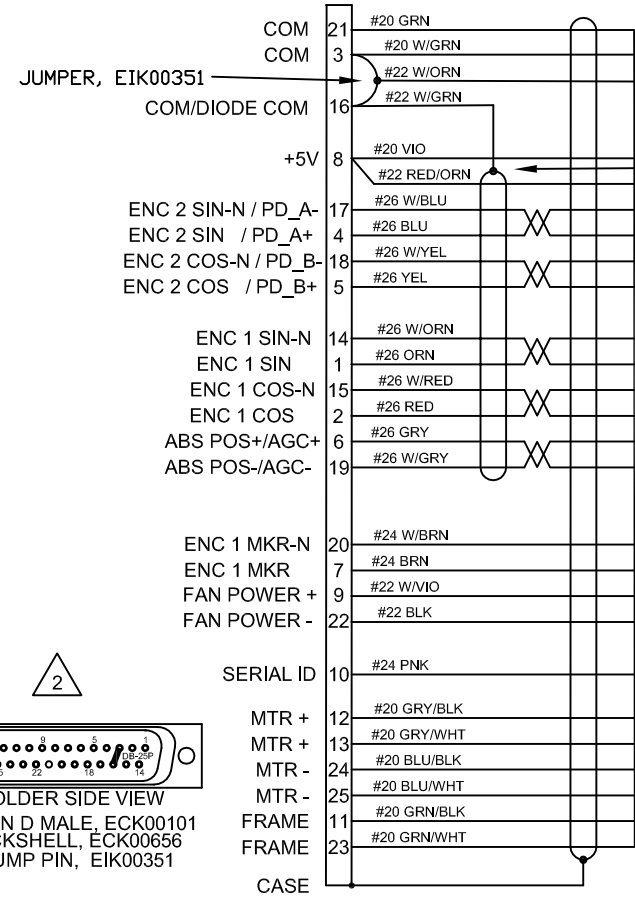

SPLICE/INSULATE
(INNER SHIELD MUST BE
ISOLATED FROM OUTER SHIELD)

ECX01371, 26 COND.
#26x2x5 TP, #22x4, #20x9, #22x3

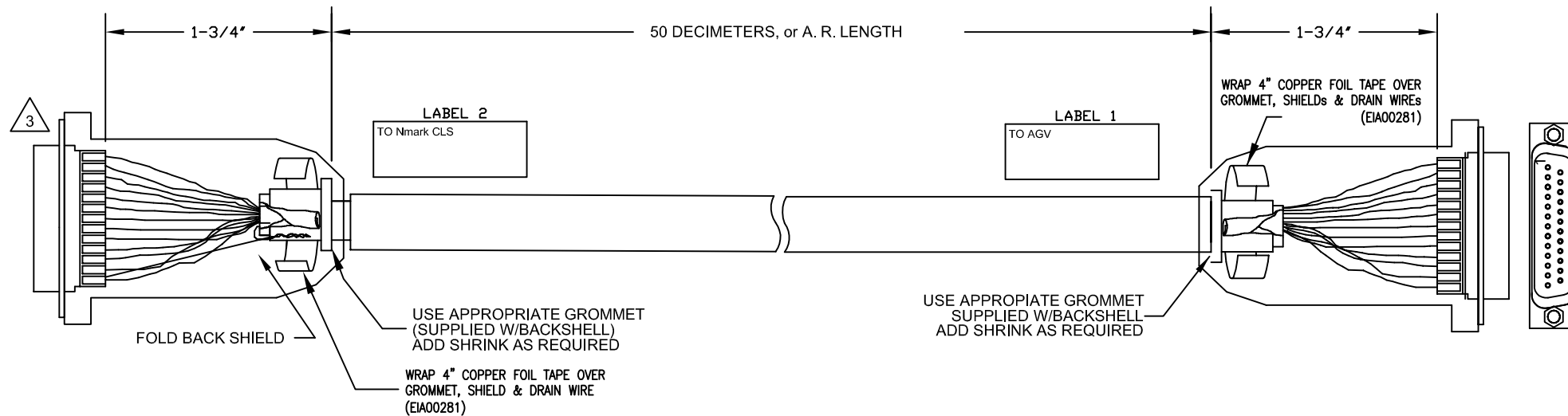
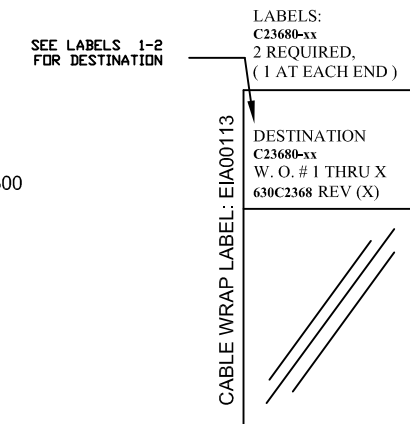
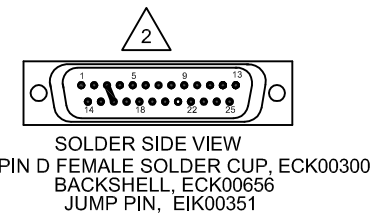
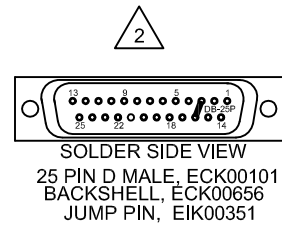
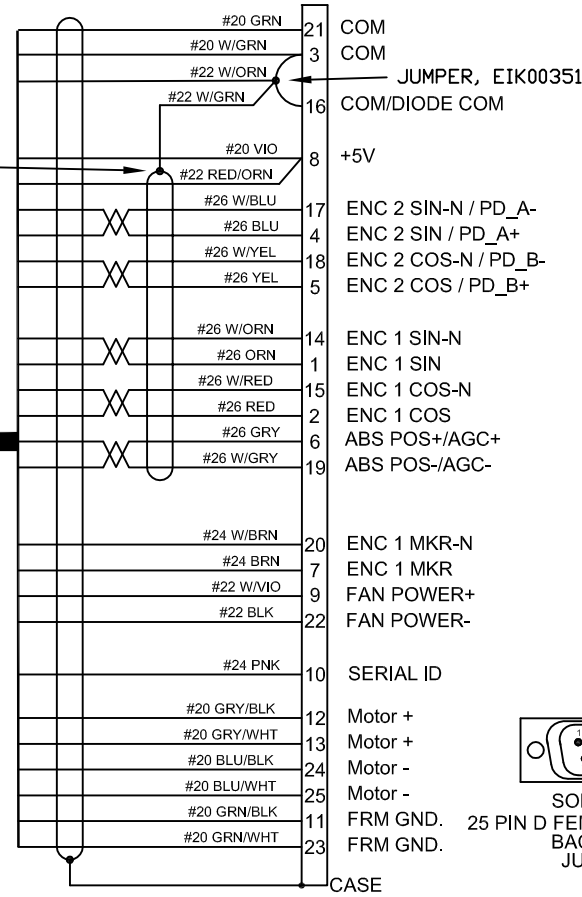

- 4 IF MANUFACTURED BY OUTSIDE VENDOR SEND 682B1191 DRAWING
- 3 SIGNIFIES A TWISTED PAIR OF WIRES, NOT A SPLICE/CONNECTION.
- 2 APPLY SHRINK TUBING TO ALL WIRE/SOLDER-CUP JOINTS. CARE MUST BE TAKEN NOT TO OVER-HEAT THE WIRES DURING SOLDERING AND THE APPLICATION OF THE SHRINK TUBING. SHRINK TUBING IS TO INSULATE ADJACENT CONTACTS AND PROVIDE STRIAN RELIEF FOR THE INDIVIDUAL WIRES.
- 1 STARTING CABLE LENGTH SHOULD BE 5 IN LONGER THAN TOTAL LENGTH OF CABLE.

PROPRIETARY INFORMATION THIS DRAWING IS THE PROPERTY OF AEROTECH, INC. AND IS SUBMITTED IN CONFIDENCE AND SHALL NOT BE REPRODUCED NOR COPIED NOR DISCLOSED TO OTHERS UNDER PENALTY OF LAW.			 AEROTECH, INC. 101 Zeta Drive Pittsburgh, PA. 15238-2897 (412) 963-7470 www.aerotech.com		
TOLERANCES ON FRACTIONS DECIMALS ANGLES 0 TO 6 ± 1/32 .XX ± .01 ± 0-30' OVER 6 ± 1/16 .XXX ± .005			<h2 style="text-align: center;">AGV To Nmark CLS</h2> <h3 style="text-align: center;">Galvo 25DU-25DU-MAX120DM</h3>		
RMS FINISH <input checked="" type="checkbox"/> EXCEPT AS NOTED					
DRAWN	11/1/2011	JFM	PART CODE	SIZE	REV.
CHECKED	11/1/2011	AGS	C23680-xx	C	-
APPD.	11/1/2011	AGS	SCALE NTS	FILE NAME	630C236801.Dwg
			SHEET	1 of 1	