

REVISIONS			
REV	DESCRIPTION	DATE	DRAWN
A	ADDED ECN 13650	10/14/2011	JFM
B	ADDED ECN 18485	7/5/2017	JFM

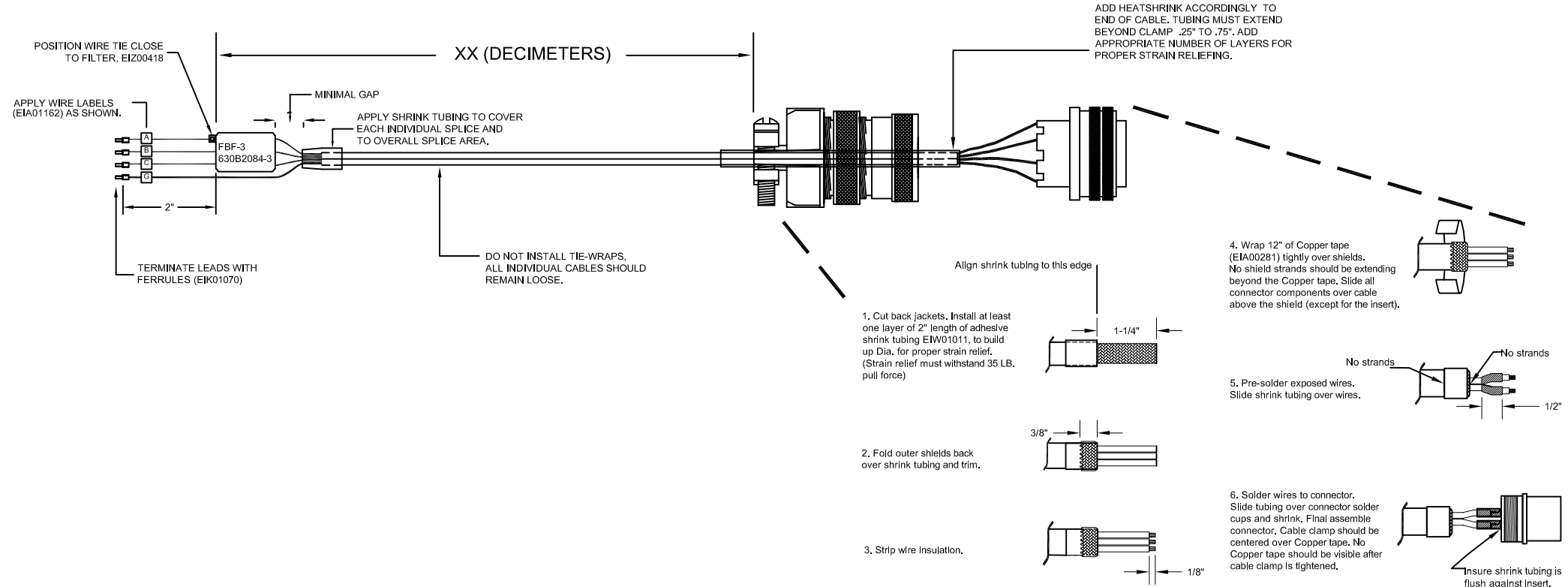
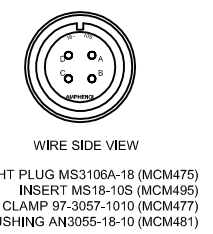
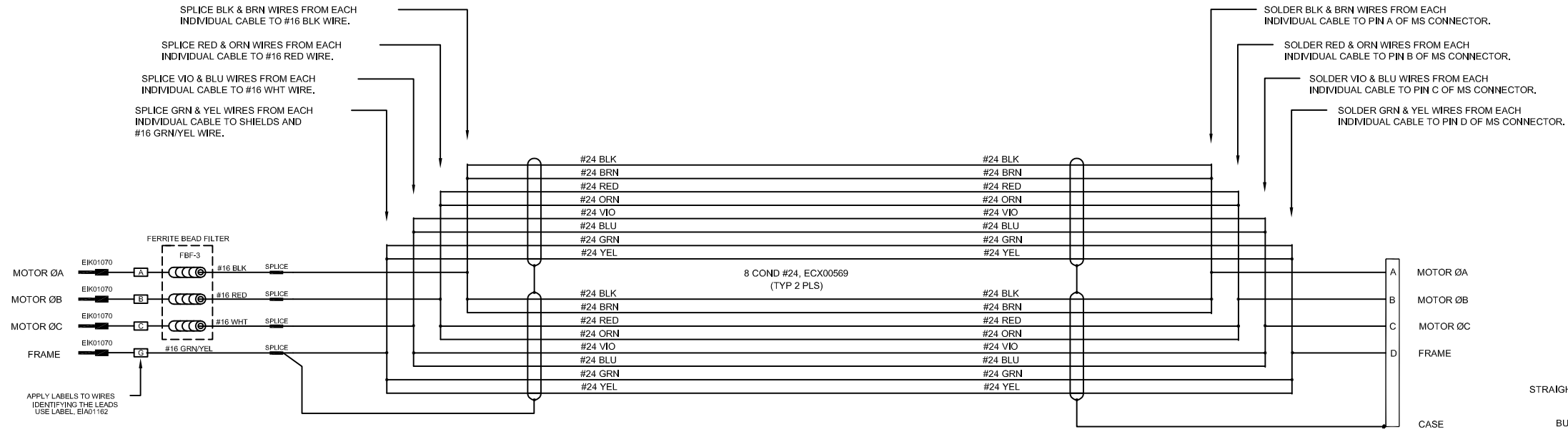

LABEL 2 REQUIRED 1 EACH END

CABLE WRAP LABEL: EIA00113

P/N: C21662-xx
 W/N: xxxxxxxx
 DWG: 630D2166-2 REV. x

PROPRIETARY INFORMATION THIS DRAWING IS THE PROPERTY OF AEROTECH, INC. AND IS SUBMITTED IN CONFIDENCE AND SHALL NOT BE REPRODUCED NOR COPIED NOR DISCLOSED TO OTHERS UNDER PENALTY OF LAW.		AEROTECH, INC. 101 Zeta Drive Pittsburgh, PA. 15238 (412)963-7470 www.aerotech.com	
BRUSHLESS MOTOR CABLE			
CABLE: BL MTR-FLB-4MS-HF60-10ARMS-MAX450DM			
TOLERANCES ON FRACTIONS	DECIMALS	ANGLES	
0 TO 6 3/32	XX ±0.1	° 0-30'	
OVER 6 1/16	.XXX ±0.05		
RMS FINISH	EXCEPT AS NOTED		
DRAWN	MS	9/22/09	PART CODE
CHECKED	AGS	9/22/09	SIZE
APPD.	AGS	9/22/09	SCALE FULL
			FILE NAME
			630D2166-2.DWG
			SHEET
			1 OF 1